

WaterTec Dust

200 WOG LUG STYLE BUTTERFLY VALVE – Lever Handle

Figure: BL-1000 Series



Temperature range of seats	
Material	Range
Buna-N	-12°C~+93°C
EPDM	-30°C~+140°C
Neoprene	-7°C~+107°C
Hypalon	-18°C~+149°C
Viton	-12°C~+140°C
PTFE	-20°C~+121°C

Valves meet MSS-SP67 & API 609
Flange drilling to: ANSI B16.1 Class 125/150
Testing to: API 598

Materials:

No.	Part Name	BL-1000-11 DBL/DEL	BL-1000-22 DBL/DEL
1	Body	Cast Iron	Cast Iron
2	Disc	Ductile Iron*	CF8M SS 316
3	Stem	SS 410	SS 410
4	Seat	Buna-N/EPDM	Buna-N/EPDM
5	Bushing	PTFE	PTFE
6	O-Ring	Buna-N	Buna-N
7	Pin	Carbon Steel	Carbon Steel
8	Hand lever	Malleable Iron	Malleable Iron
9	Name Plate	Aluminum Plate	Aluminum Plate
10	Position	Carbon Steel	Carbon Steel

* Nickel plated

Test Pressures	Shell: 300 psi
	Seat: 220 psi

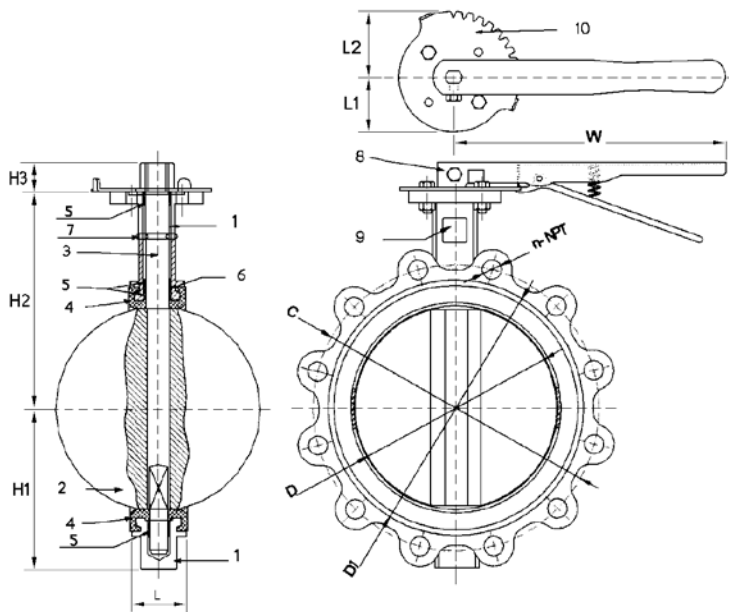

Note: Seat materials are capable of withstanding lower temperatures without damage. However, the elastomer becomes hard and torques increase. Some flow media may further restrict the published temperature limits and/or significantly reduce seat life.

Options:

Seats: Buna-N, EPDM, Hypalon, Viton, Neoprene, PTFE.

Disc: Nickel plated Ductile iron, nylon coated ductile Iron, aluminum bronze, 316 stainless steel.

Body: Cast iron, ductile iron.

Note: Please refer to "Numbering System" sheet to obtain detailed figure numbers.

Caution: All 1000 series valves must be installed in the partial open position. Installing in the full closed position may damage the seat during start up and void any warranties.

Dimensions:

Size		D		L		H1		H2		H3		Flange			L1		L2		W		Weight			
in	mm	in	mm	in	mm	in	mm	in	mm	in	mm	in	mm	in	mm	in	mm	in	mm	lb	kg			
2	50	2	51	1.7	43	2.8	71	5.5	140	1.3	33	4.8	120.7	3.7	95	4 - 5/8"	1.9	50	2.6	67	10.4	265	9.5	4.3
2½	65	2.5	62.8	1.8	45.8	3.1	78	6	152	1.3	33	5.5	139.7	4.3	109	4 - 5/8"	1.9	50	2.6	67	10.4	265	12	5.5
3	80	3.1	78	1.8	45.8	3.9	100	6.3	159	1.3	33	6	152.4	5	127	4 - 5/8"	1.9	50	2.6	67	10.4	265	12	5.6
4	100	4	102.5	2	52	4	102	7	178	1.3	33	7.5	190.5	6	152	8 - 5/8"	1.9	50	2.6	67	10.4	265	21	9.4
5	125	4.8	121.5	2.2	55.5	4.6	118	7.5	191	1.4	37	8.5	215.9	7.2	182	8 - 3/4"	1.9	50	2.6	67	10.4	265	28	12.7
6	150	6	154	2.2	55.5	5.1	130	8	204	1.37	35	9.5	241.3	8	207	8 - 3/4"	1.9	50	2.6	67	10.4	265	29	13.1
8	200	7.9	201	2.3	59.5	6.4	163	9.4	238	1.7	43	11.8	298.5	10.4	264	8 - 3/4"	2.7	70	3.4	87	14	357	43	19.5
10	250	9.8	249	2.6	67.2	7.8	198	10.6	270	1.5	38	14.3	362	12.5	317	12 - 7/8"	2.7	78	3.5	90	14	357	63	28.5
12	300	11.8	300	3	77	9.3	235	12.4	315	1.7	43	17	431.8	14.6	370	12 - 7/8"	2.7	78	3.5	90	14	357	92	42